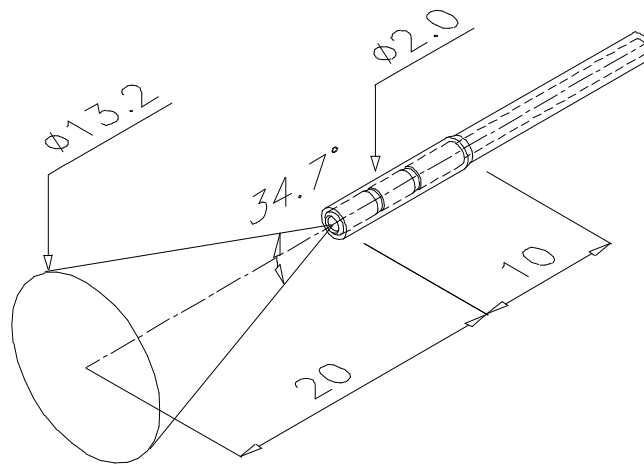

Ch. des Larges-Pièces B, CH-1024 Ecublens

phone: +41 / 21 - 697 - 07 75  
fax: +41 / 21 - 697 - 07 79  
e-mail: info@medlight.com  
web site: www.medlight.com

## Frontal light distributor Model FD

**CE 1253**

### DESCRIPTION

The FD1 frontal light distributor produces a circular spot of light, with sharp edges and an outstanding homogeneity. These properties make it the ideal device for precise irradiation of a variety of organs treated with photodynamic therapy (PDT) in patients or animals (skin, head and neck, lungs, etc.). The uniform light pattern is also perfectly suited for illuminating cell cultures or to be used as a calibration source for light sensors.

Its particularly wide aperture angle is very useful when there is little space to irradiate the tumour. This is often the case when performing PDT endoscopically, for instance by treating bronchial spurs. The small overall diameter of 2 mm allows endoscopic use through the working channel of a standard fiberscope. The FD1 frontal light distributor works with wavelengths ranging from 480 nm to 800 nm, making it suitable for a variety of photosensitisers.

This device is supplied sterile and may be re-used, with a maximum of 10 re-uses. Suitable cleaning, decontaminating and disinfecting of the FD1 frontal light distributor is performed according to standard endoscopic material procedures. If sterilization is needed before re-using the FD1 frontal light distributor, Ethylene Oxide (EtO) sterilization is recommended with following parameters: 50°C / 55% RH / 4h exposure to EtO gas.

**TECHNICAL DATA**  
(subject to change without notice)

<b>MECHANICAL DIMENSIONS</b>	<b>FD1</b>
OVERALL DIAMETER	2 mm
OVERALL LENGTH	4 m
<b>OPTICAL CHARACTERISTICS</b>	
TRANSMISSION (*)	> 85 %
FULL ANGLE OF DIVERGENCE	34.7°
BEAM DIAMETER	
at 0 mm DISTANCE:	0.6 mm
at 10 mm DISTANCE:	7.6 mm
at 20 mm DISTANCE:	13.2 mm
UNIFORMITY	± 15%
<b>LASER INPUT</b>	
MAXIMUM POWER (calibrated fiber output)	2.0 W (cw)
WAVELENGTH RANGE	480 – 800 nm
<b>OPTICAL FIBER</b>	
FIBER MATERIAL	SILICA, low OH <sup>-</sup>
CORE DIAMETER	600 µm
NUMERICAL APERTURE	0.37
MINIMUM BENDING RADIUS	94 mm
FIBER CONNECTOR	SMA 905

(\*) Transmission is defined in comparison with a 5 meters / 600 microns / NA 0.37 silica bare fiber.

**TYPICAL LIGHT INTENSITY PROFILE**

(FD1, distance to screen: 100 mm)

